



Valco Instruments Co. Inc.

**Pulsed Discharge
Detector
Model D-4-I-SH14-R
Instruction Manual**

Rev 1/15

North America, South America, and Australia/Oceania contact:

VICI® **Valco Instruments Co. Inc.**
800 · 367 · 8424 sales
713 · 688 · 9345 tech
713 · 688 · 8106 fax
valco@vici.com

Europe, Asia, and Africa contact:

VICI **VICI AG International**
Schenkon, Switzerland
Int + 41 · 41 · 925 · 6200 phone
Int + 41 · 41 · 925 · 6201 fax
info@vici.ch

This page intentionally left blank for printing purposes

Table of Contents

Introduction	
Description and Operating Principles	1
Safety Notes and Information	2
Components of the Detector System	3
System Requirements	
Components not Included with the Detector System	4
System Purity	4
Gas Specifications	5
Installation	
General Precautions	6
Mounting the Detector on the GC	6
Gas Connections	7
Installing and Purging the Gas Regulator	7
Installing and Purging the Helium Purifier	8
Connecting the Discharge Gas to the Detector	8
Pulser Module Installation	9
Detector Electrical Connections	10
Initial Power-Up	10
Capillary Column Connection	12
Packed Column Connection	12
Testing for Leaks	13
Mode Selection and Setup	
Helium Ionization Mode	14
Selective Photoionization Mode	14
Troubleshooting	16
High Background Current	16
Low Sensitivity	16
No Peaks	16
High Noise Level	17
Performing a Hydrogen Leak Test	17
Warranty	18
Detector Performance Log	19

This page intentionally left blank for printing purposes

Introduction

Description and Operating Principle

The PD-D-4-I-SH14-R is a non-radioactive pulsed discharge ionization detector (PDID) which is optimized for the Shimadzu 14 GC. A schematic representation of the basic D4 detector is shown in **Figure 1**.

The D4 utilizes a stable, low power, pulsed DC discharge in helium as the ionization source. Elutants from the column, flowing counter to the flow of helium from the discharge zone, are ionized by photons from the helium discharge above. Resulting electrons are focused toward the collector electrode by the two bias electrodes.

The principal mode of ionization is photoionization by radiation arising from the transition of diatomic helium $\text{He}_2(A^1\Sigma^+)$ to the dissociative $2\text{He}(1S^1)$ ground state. This is the well-known Hopfield emission. The photon energy from the He_2 continuum is in the range of 13.5 eV to 17.7 eV.

The D4 is essentially non-destructive (0.01 - 0.1% ionization) and highly sensitive. The response to organic compounds is linear over five orders of magnitude with minimum detectable quantities (MDQs) in the low picogram range. The response to fixed gases is positive (the standing current increases), with MDQs in the low ppb range.

Detector response is universal except for neon, which has an ionization potential of 21.56 eV. Since this potential is close to the energy of the He^* metastable (19.8 eV) but greater than the photon energy from the He_2 continuum, neon exhibits a low ionization efficiency and low detector response.

When a dopant is added to the discharge gas, the D4 also functions as a selective photoionization detector. (Suitable dopants include Ar for organic compounds, Kr for unsaturated compounds, or Xe for polynuclear aromatics.)

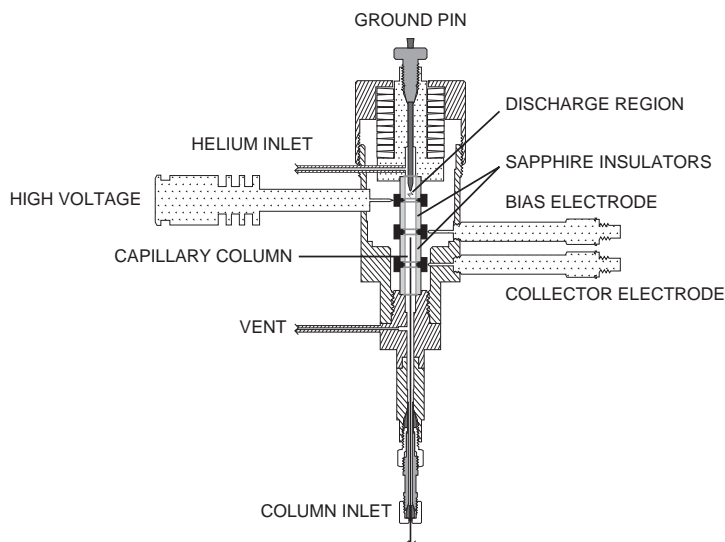

Figure 1: Schematic of the D4 detector

Helium Ionization (PDHID)

The PDHID is essentially non-destructive (0.01 - 0.1% ionization) and highly sensitive. The response to organic compounds is linear over five orders of magnitude with minimum detectable quantities (MDQs) in the low or sub picogram range. The response to fixed gases is positive (the standing current increases), with MDQs in the low ppb range.

The PDHID response is universal except for neon, which has an ionization potential of 21.56 eV. Since this potential is close to the energy of the He* metastable (19.8 eV) but greater than the photon energy from the He₂ continuum, neon exhibits a low ionization efficiency and low detector response.

Photoionization (PDPID)

Changing the discharge gas from pure helium to helium doped with argon, krypton, or xenon changes the discharge emission profile, resulting in resonance atomic and diatomic emissions of the rare gas added. Response is limited to sample compounds with ionization potentials less than or equal to the dopant gas emission energy. In this configuration, the detector is essentially functioning as a specific photoionization detector for selective determination of aliphatics, aromatics, and amines, as well as other species. Since there is no lamp or window, sensitivity will not change with time.

Safety Notes and Information



CAUTION: During normal operation, the detector produces ultraviolet energy (UVA, UVB), some of which may be emitted. Do not watch the arc without eye protection.

Symbols



HIGH VOLTAGE

Voltages presenting the risk of electric shock are present in several places in the equipment. Avoid contact with hazardous live parts. Do not probe into openings or attempt to defeat safety mechanisms.



HOT SURFACE

The surface of the detector body may be hot while in operation (possibly in excess of 250°C). Caution should be observed.



ATTENTION

Refer to the manual.



PROTECTIVE EARTH

This internal connection provides protection against electric shock from mains voltages and should not be removed.

Components of the Detector System

Components of the detector system are listed in the **Table 1**. Check the contents of the packages to verify that everything is present. Contact the factory if anything is missing or damaged. (NOTE: damaged shipments must remain with the original packaging for freight company inspection.)

Table 2 lists additional required items which must be purchased from Shimadzu.

Table 1: Components of the D-4-I-SH14-R system

Description	Quantity	Product number
Detector cell, PDHID	1	PD-D4-I-RU
Pulse supply module	1	PD-M2
Instruction manual	1	MAN-PDD4-SH14
Fittings kit	1	PD-KIT-D4
<i>Includes:</i> 1/32" polyimide ferrule	5	ZF.5V
1/16" gold-plated ferrule	5	ZF1GP
0.25 - 0.44 mm polyimide column ferrule	5	FS.4
0.4 - 0.5 mm polyimide column ferrule	5	FS.5
1/16" union, 316 SS	2	ZU1MS6
1/16" tee	1	ZT1
1/8" external to 1/16" internal adapter	2	EZR21
1/8" external to 1/16" internal reducing union	2	EZR21
1/32" external nut	1	EN.5KN
Packed column adapter	1	I-23642-D4RU
Restrictor, 30 cc/min @ 60 psi He	1	TGA-R-30F60P
Helium purifier	1	HP2
Electrometer cable assembly, Shimadzu	1	I-23230-SH14
Bias cable assembly, Shimadzu	1	I-23404-SH14
Pulser power supply	1	I-23569-I
Heater block, Shimadzu GC14	1	I-23911
Cover plate, Shimadzu GC14	1	I-23823

Table 2: Components not supplied by Valco (may be obtained from Shimadzu)

Description	Quantity	Product number
Electrometer, FID GC14	1	221-36965-91

System Requirements

Components Not Included with the Detector System

- Helium (99.999% purity) and other support gases
- Ultra high purity grade gas pressure regulator with stainless steel diaphragm
- Any special adapters required for connection to the gas regulator
- SS tubing to go from gas supply to GC
- Flow measuring device

System Purity

Discharge/Carrier Gas Considerations

The performance of the detector is adversely affected by the presence of any impurities in the gas streams (carrier, discharge, or dopant). We recommend that a quality grade of helium 5.0 (99.999% pure or better) be used at all times. Major gas suppliers offer research grade helium (99.9999% pure) which is particularly low in fixed gas impurities and should give good results in a clean system, but even the highest quality carrier gas may contain some water vapor and fixed gas impurities; hence a helium purifier is included as part of the detector system. *The discharge gas must **always** flow through the helium purifier.*

Whenever a new batch of discharge gas is received, we recommend performing a blank GC analysis of the gas in the PDHID mode to detect and identify the presence of any impurities. Gas purity requirements are specified on the next page.

Tubing

Standards of cleanliness that are suitable for many GC applications may be totally inadequate for the sensitive PDHID/PDPID work. All surfaces that contact the gas stream must be fused silica or stainless steel. Do not use copper tubing or brass fittings. All tubes must be thoroughly cleaned and baked before use.

Flow Controllers

The use of valves or flow controllers in which the gas stream is exposed to any polymer-based packing or lubricating material is to be particularly avoided.

Pressure Regulators

We recommend commercial “ultra-pure” grade regulators with stainless steel diaphragms. Regulators with diaphragms made of neoprene or other elastomers should never be used.

Gas Specifications

	Detector Mode			
	PDHID	Ar-PDPID	Kr-PDPID	Xe-PDPID
Discharge gas	Helium	2% Ar in He	1.5% Kr in He	0.8% Xe in He
Carrier gas	Helium	*	**	**

* Any gas including He which has an ionization potential greater than 12 eV

** Any gas including He which has an ionization potential greater than 11 eV

Purity Specifications

- Helium (discharge and carrier gas) must have a minimum purity of 99.999%, with < 20 ppm Ne impurity. For trace analysis of fixed gases, we strongly recommend 99.9999% purity He with < 0.5 ppm Ne.
- Ar-PDPID mode: 2% \pm 0.2% Ar in 99.999% He balance
- Kr-PDPID mode: 1.5% \pm 0.1% Kr in 99.999% He balance
- Xe-PDPID mode: 0.8% \pm 0.2% Xe in 99.999% He balance

Installation

General Precautions

- Do not use plastic/polymer or copper tubes for gas handling and interconnects. Use only stainless steel tubing with Valco gold-plated ferrules.
- Do not turn the unit on until the helium discharge gas is flowing through the detector.
- Do not shut off or disconnect the discharge gas when the detector is hot, even if the unit is turned off. Turn off the discharge and allow the detector to cool down naturally before disconnecting or shutting off the discharge gas.
- Do not cover the unit with materials or devices which would restrict air circulation.
- Position the controller unit where the mains switch on the rear panel can be reached easily.

Mounting the Detector on the GC

1. Remove the cover plates and insulation on detector position #4 (to the right). Remove the heater block screw. (NOTE: The detector will also fit in Position #2, but the cover plate supplied with the detector will not fit.)
2. Place the detector on the top of the GC as shown in **Figure 3** and secure it with the heater block screw.
3. Install the cover plate provided by Valco as part of the detector system.

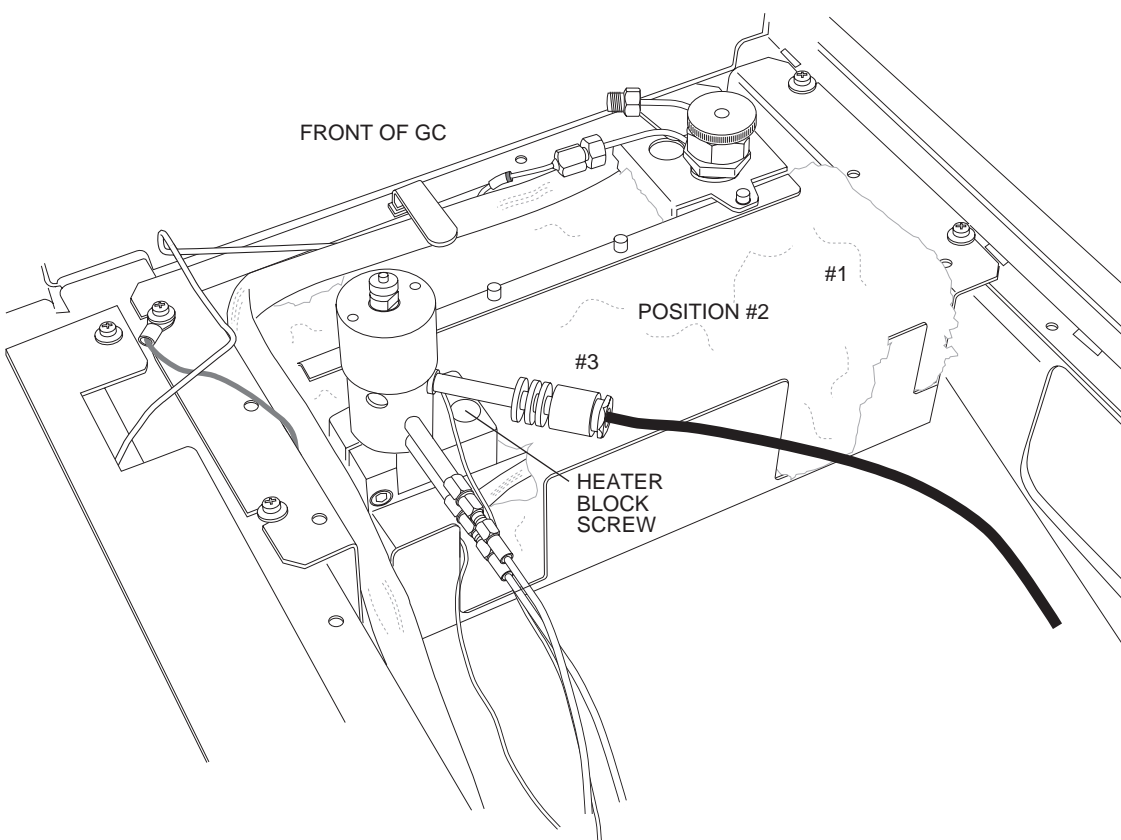

Figure 3: Mounting the detector on the GC

Gas Connections

Remember these three points discussed earlier: (1) all surfaces that contact the gas stream must be fused silica or stainless steel; (2) do not use copper tubing or brass fittings; and (3) all tubes must be thoroughly cleaned and baked before use. The installation instructions below assume that the detector discharge gas will be supplied from a nearby cylinder of helium of the proper purity. If your installation is different, you may need to modify the instructions appropriately. A number of Valco fittings have been supplied in the fittings kit to handle different situations.

Figure 4 illustrates gas connections for the D-4-I-SH14-R detector system. Since the distance from the helium supply to the GC varies from installation to installation, we do not supply tubing for that purpose.

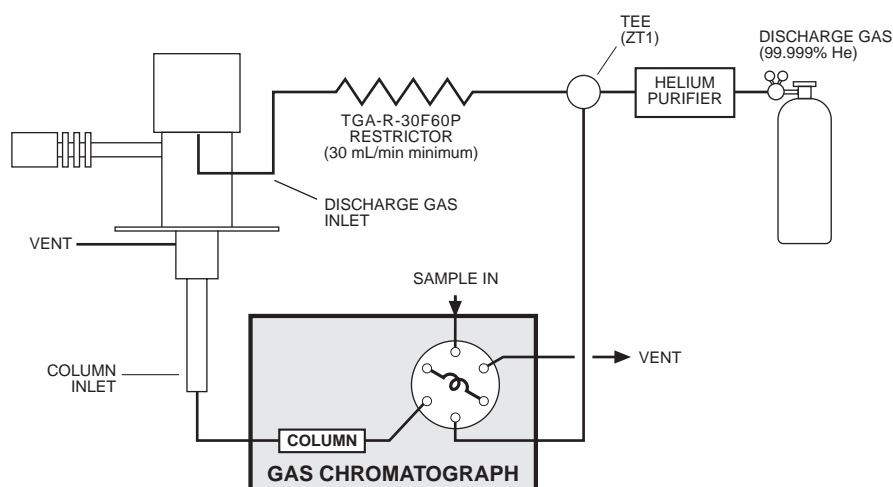

Figure 4: Gas connections for a D-4-I-SH14-R system

Installing and Purging the Gas Regulator

1. Make sure the on/off valve on the helium cylinder is completely closed. Screw the CGA fitting nut of the regulator into the helium cylinder. Go beyond finger-tight, but do not tighten the nut all the way – some leakage is required for the purging operation.
2. Turn the output pressure regulating knob completely counterclockwise.
3. Open the cylinder on/off valve *slightly* and quickly close it again.
4. Adjust the tightness of the regulator connecting nut to allow a pressure reduction of ~690 kPa/sec (100 psi/sec). With a new bottle, the gauge should start out at about 14 MPa (2000 psi).
5. When the pressure drops into the 1.4 - 3.4 MPa (200 - 500 psi) range, open the cylinder on/off valve slightly and quickly close it again.
6. Repeat Step 5 eight or ten times to be certain that all the air is purged. On the final purge, tighten the regulator connecting nut very securely as the pressure approaches the 2.1 - 3.4 MPa (300 - 500 psi) range.

7. Open the cylinder valve to pressurize the regulator once again. Close the valve and observe the needle of the high pressure gauge for 15 minutes. If it doesn't move, there is no critical leak on the high pressure side of the regulator.



CAUTION: Never use leak detecting fluids on any part of this system.

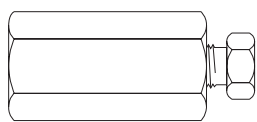

EZR21

Installing and Purging the Helium Purifier

1. If the pressure regulator has a 1/8" *male* cone-type outlet port, install the Valco 1/8" external to 1/16" internal reducer (EZR21); if it has a 1/4" *male* cone-type outlet port, install the Valco 1/4" external to 1/16" internal reducer (EZR41). For other regulator outlet fittings, a wide variety of Valco adapters is available.
2. Remove the cap from the inlet tube of the Valco helium purifier and insert the tube fitting into the 1/16" reducer port. (Keep the outlet tube capped.) Use a 1/4" wrench to turn the nut one-quarter turn past the point where the ferrule first starts to grab the tubing. Do not remove the fitting. When made up properly, it should be leak-tight.
3. Turn the output pressure regulating knob clockwise until the gauge registers 345 KPA (50 psi).
4. Allow five minutes for equilibration, then turn the regulating knob all the way counterclockwise.
5. Observe the needle of the output pressure gauge for 15 minutes. There will be a slight initial drop, but if it doesn't move after that, consider that all the connections are tight.
6. If necessary, use an electronic leak detector to locate any leaks. If a leak detector is not available, tighten all the fittings (including the output pressure gauge), and repressurize the system for another test.
7. Upcap the outlet tube of the purifier and purge the system for 15 to 30 minutes at 60 - 80 mL/min to eliminate air from the purifier getter material.

Connecting the Discharge Gas to the Detector

1. If you are supplying the GC from the helium purifier, use the Valco ZT1 tee. Otherwise, use one of the Valco 1/16" unions (ZU1) to connect the outlet tube of the purifier to the inlet of the supplied discharge gas restrictor (TGA-R-30F60P).
2. Connect the outlet end of the restrictor to a flow measuring device. Adjust the helium pressure to 60 psi to obtain a continuous flow of ~30 mL/min.
3. After setting the flow rate, connect the outlet of the restrictor to the discharge gas inlet tube (labelled "INLET") which comes out the side of the detector.

Pulser Module Installation

1. Mount the pulser module as shown above in **Figure 5**.
2. Power to the pulser module is provided through the pulser power supply (PN I-23569-1). Plug the 4-pin connector into the pulser module.

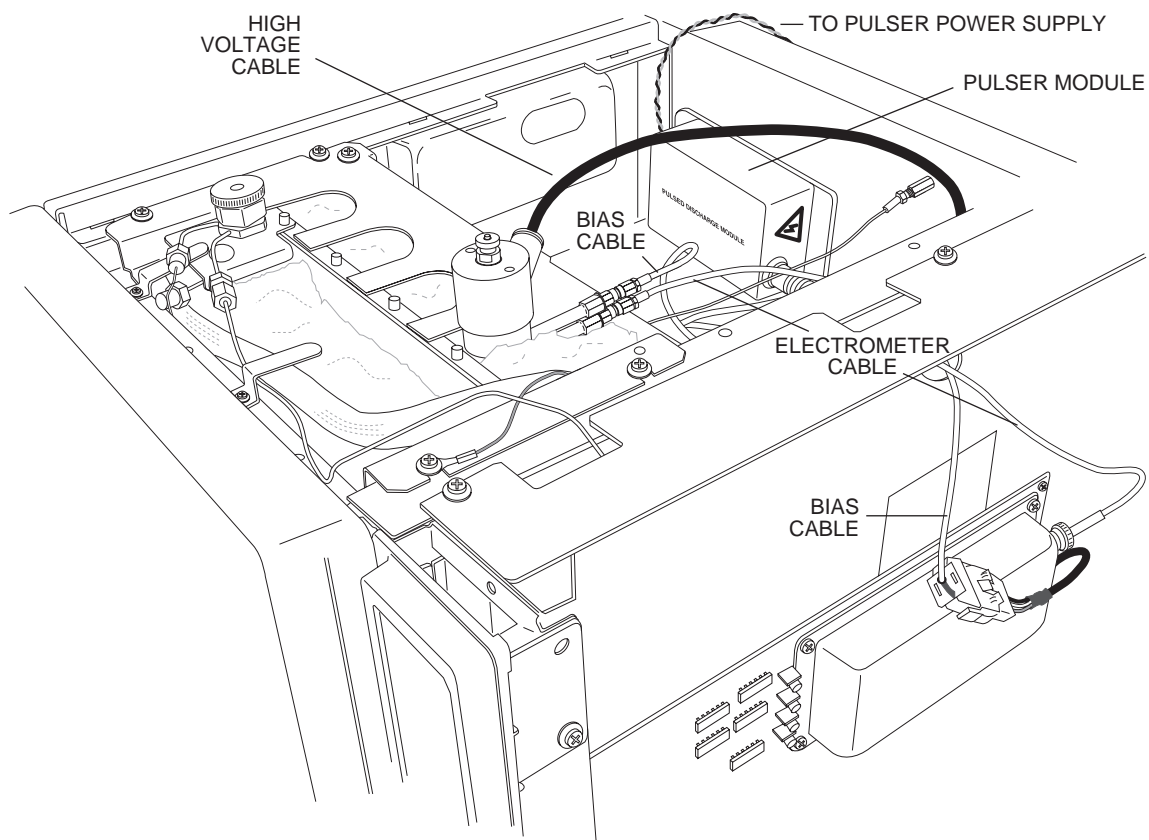

Figure 5: Mounting the pulser module

Detector Electrical Connections



CAUTION: Do not use a wrench to tighten the SMC connectors on the bias and electrometer cables. Connections should be finger tight only.

1. Referring to **Figures 5** and **6** as necessary, connect the **BIAS** cable to the top electrode and the electrometer cable (**ELECT**) to the bottom electrode.
2. Connect the high-voltage cable from the detector to the pulse supply.

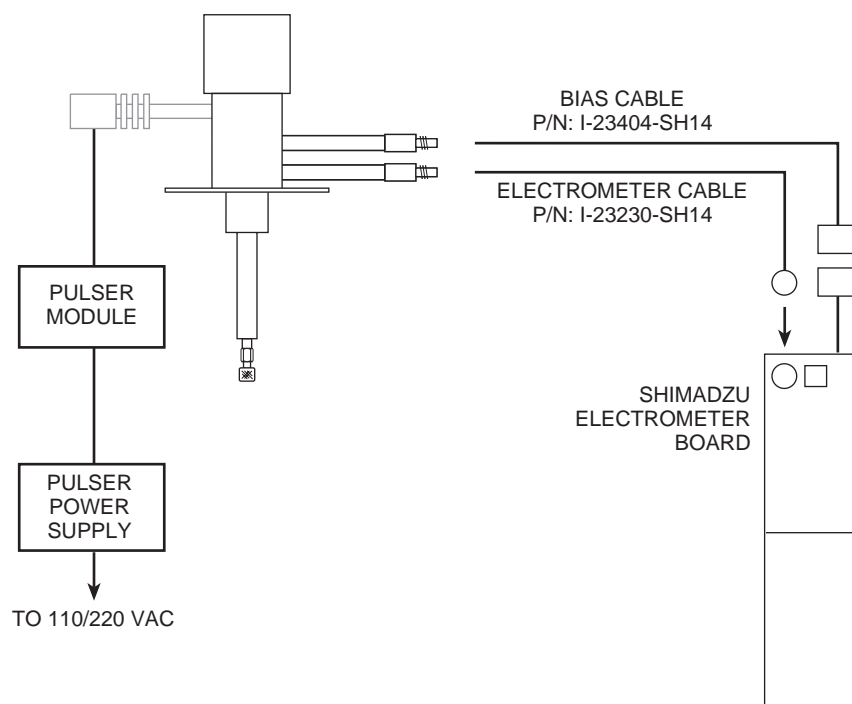

Figure 6: Schematic of electrical connections

Initial Power-Up



CAUTION: Always make sure that discharge gas is flowing before heating and powering up the detector.

1. Before installing the column, set the gas flow to 30 ml/min (measured at the detector vent). Let it flow for 15 minutes so that all air is purged from the helium purifier.
2. Plug in the helium purifier and turn on the GC.

3. Set the detector temperature to 100°C and allow time for the detector and helium purifier to reach the set temperature.
4. Set the range to 10² and adjust the voltage to Ø.
5. Plug the 15 VDC output from the power supply (I-23569-1) into the pulser module (PD-M2).
6. Plug the power supply cord to a 100 - 250 VAC source, and look through the hole in the detector housing to see that the discharge is on.



CAUTION: During normal operation, the detector produces ultraviolet energy (UVA, UVB), some of which may be emitted. Do not watch the arc without eye protection.

7. Check the standing/background current. Optimum range is 6.0 - 20.0 mV (0.60 - 2.0 nA) at 100°C in the HID mode. Lower current indicates a clean, leak-free system. Record the standing/background current in the Detector Performance Log on the last page of this manual.
8. The recommended detector temperature is 20°C above the column temperature, with a minimum of 100°C. Set the detector to the operating temperature required for the intended analysis. When the detector has reached the set temperature, read and record the standing current.
9. Install the column as illustrated on page 12, leaving the oven at ambient temperature. Start carrier flow, then read and record the standing current.
The difference between this reading and the one previous is the ionization of the combined impurities in and eluting with the carrier gas. The smaller the difference, the better the quality of the gas exiting the column.
10. Set the column oven to the temperature required for the intended analysis. When the oven reaches the set temperature, read and record the standing current.
The difference with the previous reading is the ionization of the column bleed. The smaller the difference, the better the column is conditioned.
NOTE: Some stationary phases will have a higher bleed than others, but are still suitable for this detector. However, the lower the bleed, the lower the chances of contaminating the detector cell.

From this point, the standing current should be observed and logged after any system change. In addition, logging the standing current (with and without the column) on a regular basis is an effective monitor of system integrity (leaktightness and cleanliness). We also recommend tracking the internal standard (quantity on column/area count) for sensitivity continuity.

Capillary Column Connection

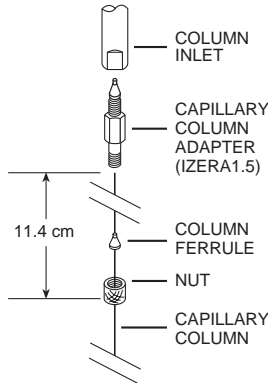

If the capillary column adapter is installed in the column inlet:

1. Make a mark on the column 11.4 cm from the end.
2. Remove the knurled nut and plug from the capillary column adapter in the column inlet at the bottom of the detector. Slide the nut over the end of the column, followed by the appropriate column ferrule (FS.4 or FS.5, or ZF.5V for megabore).
3. Seat the ferrule in the detail of the column adapter and begin sliding the column through the capillary column adapter and into the column inlet.
4. Get the nut started on the threads and tighten it until you feel it contact the ferrule, then back off half a turn. Slide the column into the column inlet until the mark is flush with the surface of the knurled nut, and secure the column in the adapter by tightening the knurled nut *finger tight only*.

If the capillary column adapter has been removed, reinstall it:

1. Unscrew the liner as far as it will go, then screw the fitting body into the column inlet fingertight.
2. While using a 1/8" wrench to prevent rotation of the liner (the part with the seat for the column ferrule), use a 1/4" wrench to tighten the body of the adapter until the ferrule has sealed. The liner *will deform* if it rotates.
3. Proceed to Step 1 above.

Packed Column Connection



To prevent detector contamination, we strongly recommend disconnecting the column from the detector during column bakeout procedures.

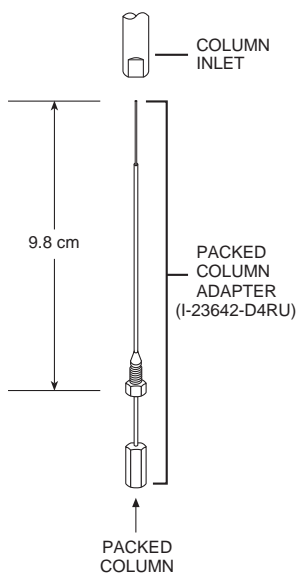

The D4 is optimized for packed columns. The column tubing must be thoroughly cleaned and baked before the column is packed. Even when the best care is taken in column tubing cleaning and in the support and stationary phase selection, a new column will often bleed compounds, resulting in a considerable increase in the detector baseline. This initial bleed will usually be reduced to acceptable levels after the column is conditioned with clean carrier gas flow for several hours at the recommended bakeout temperature.

1. Loosen and remove the knurled nut and plug of the capillary column adapter, (or remove the column ferrule and the column if one has been installed).
2. Use a 1/8" wrench to hold the liner – that part of the adapter in which the column ferrule sits. While the 1/8" wrench keeps the liner from rotating, use a 1/4" wrench on the fitting body to loosen the adapter 1/2 turn.

3. Set aside the 1/8" wrench and completely remove the adapter from the column inlet.
4. Screw the packed column adapter into the column inlet by hand. *Exercise caution*, as the tip of the adapter is very fragile. Then tighten the adapter with a 1/4" wrench, using an additional wrench on the flats of the column inlet to support the detector.
5. Connect the 1/8" column to the packed column adapter with the EZRU21 reducing union supplied in the fittings kit.

Testing for Leaks

It is critical for the system to be leak-tight, and an additional check at this point can save many headaches later on. To test for leaks:

1. Cap the tube and pressurize the entire system with helium to 138 kPa (20 psi).
2. If the system does not hold pressure, check all the fittings with an electronic helium leak detector.



CAUTION: Never use leak detecting fluids on any part of this system.

3. Tighten fittings as required.

An alternative leak testing method is described on page 17. NOTE: A leak upstream from the column will not cause an immediate baseline change. There must be time allowed for the hydrogen to pass through the column.

Mode Selection and Setup

Helium Ionization Mode

If the instructions of Step 1 at the top of page 9 were properly executed, the column should already be properly positioned. Since there may be some variation in the flow rate for the different types of capillary columns, the user may want to optimize the column position within this suggested range. DO NOT insert the column more than 11.6 cm.

With this flow configuration, only pure helium passes through the discharge region, minimizing the chance of discharge electrode contamination through contact with the eluting sample. However, if very high concentrations of organic compounds are introduced for extended periods of time, they could diffuse into the discharge region and contaminate the electrodes. Under normal chromatographic use with capillary columns, such contamination is negligible even over extended periods.

Selective Photoionization Mode



To maximize detector lifetime, turn off the discharge power when the GC is not actually analyzing samples. This is especially important in the Ar/Kr PID mode.

Since the pulsed discharge detector is essentially a windowless helium photoionization detector, changing the discharge gas from pure helium to helium doped with argon, krypton, or xenon changes the discharge emission profile. This results in a change in the photon energy due to additional resonance atomic emissions and diatomic emissions from the rare gas added. Thus a single detector can be operated in any of the three photoionization detector (PID) modes: Ar-, Kr-, or Xe-PID.

Doped helium is used rather than other pure gases in order to retain the benefits of the helium: namely, its transparency for Ar, Kr, an Xe resonance radiation and its efficient cooling of the electrodes. Any problems associated with the presence of a window between the photon source and the ionization chamber are eliminated. In most applications involving current commercial PIDs, analyte condensation and decomposition on the window attenuate the lamp energy, necessitating frequent cleaning and recalibration.

Custom gas blends for the pulsed discharge detector are available from leading gas suppliers at special prices. Alternatively, they may be formulated on the spot by using appropriate fixed restrictors to mix appropriate amounts of pure helium and pure dopant through a tee. Since all gas streams must pass through a Valco purifier, the second option requires an additional purifier for each dopant. This may still be more cost effective than requesting a custom blend of the more expensive Kr or Xe; since the typical flow rate required for the pure dopant rare gas is about 0.3 - 1 mL/min, a small lecture bottle can last for a long time. In either case, the total discharge gas flow rate should be the same as specified in "Gas Connections" on page 7.

Ar-PDPID

Changing the discharge gas from helium to a mixture of 2% argon in helium changes the photon energy level from the 17 - 13.5 eV range to the 11.8 - 9.8 eV range. The argon emission consists of resonance radiation at 11.8 eV and 11.6 eV and the diatomic Ar₂ emission in the range of 9.2 - 10.3 eV. Except for fixed gases and a few organic compounds like CH₄ (IP = 12.5 eV), CH₃CN (IP = 12.2 eV) and some fluoro-chloro hydrocarbons, the majority of organic compounds have ionization potentials lower than 11.8 eV. Thus the Ar-PDPID is nearly universal, like the flame ionization detector, but without the risks associated with the presence of an open flame and hydrogen.

Kr-PDPID

The recommended proportion is 1.4% Kr in He as the discharge gas. The krypton emission consists principally of resonance lines at 10.6 eV and 10.1 eV. The Kr-PDPID can detect compounds with IP < 10.6 eV, which includes unsaturated and cyclic hydrocarbons, alcohols, aldehydes, organic acids, esters, etc.

Xe-PDPID

The recommended proportion is 0.8% Xe in He as the discharge gas. The xenon emission consists principally of resonance lines at 9.6 eV and 8.4 eV, and can detect compounds with IP < 9.6, like aromatics, ethers, alcohols, aldehydes, etc.

In addition to the specific compounds named in the three paragraphs above, certain important inorganic compounds like ammonia, hydrogen peroxide, arsenic trichloride, hydrogen sulfide, arsine, phosphine, nitric oxide, carbon disulfide etc. can be selectively detected using the appropriate photoionization mode.

Each dopant gas requires an additional helium purifier, which must be purged and conditioned in the same manner as the purifier installed on the discharge gas supply. If you are using more than one dopant, we recommend use of a Valco multiposition stream selection valve so that no fittings have to be disconnected. Not only is this convenient, it keeps the system closed, minimizing chances of contamination. When changing from one dopant to another, allow at least one hour for the old gas to be purged from the system.

Troubleshooting

High Background Current

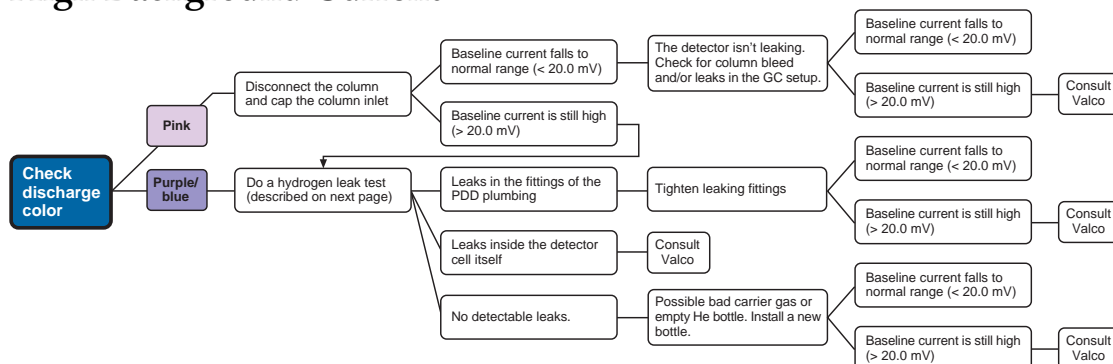

Low Sensitivity

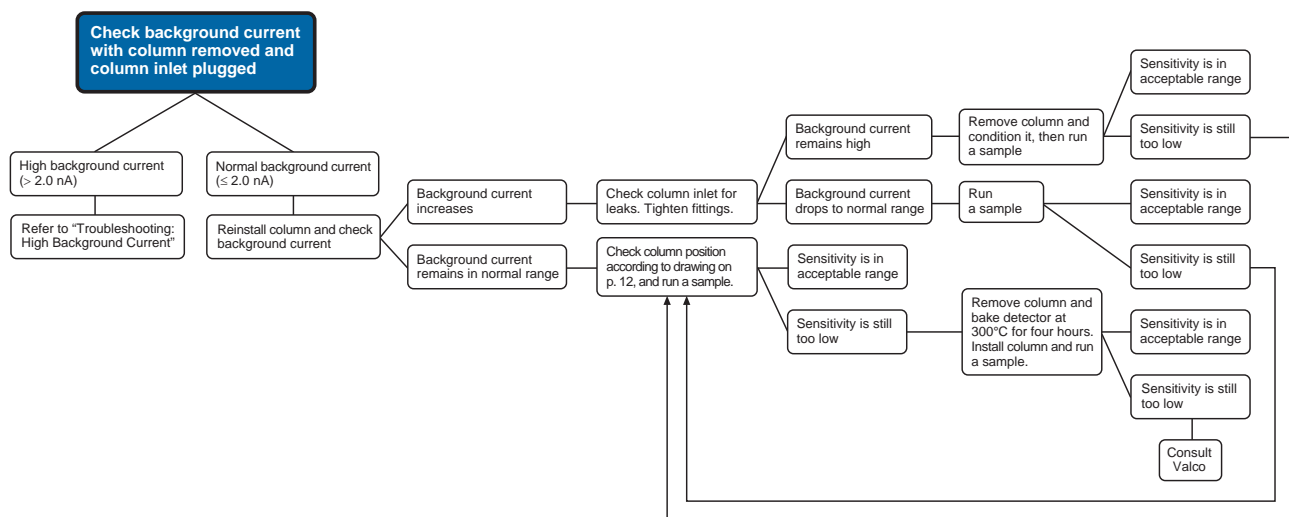

No Peaks

If the background current is stable but there are no peaks:

1. Check column flow.
2. Check the column insertion position (11.4 cm for capillary columns, 9.8 cm for packed columns).
3. If there are still no peaks, check to make sure that the GC is actually making an injection.
4. If there are still no peaks, consult Valco.

High Noise Level

If the noise level is high:

1. See if it improves with the GC fan turned off.
2. Check the column insertion position (11.4 cm for capillary columns, 9.8 cm for packed columns.)
3. If the noise level is still high, do a hydrogen leak test, described below.
4. If there are no leaks found, or leaks are found and repaired and the noise level is still high, consult Valco.

Performing a Hydrogen Leak Test

A hydrogen leak test allows you to pinpoint loose fittings and leaks inside the detector.

1. Connect a length of plastic tubing to a regulated hydrogen bottle. Establish a flow of 5-10 ml/min.
2. Hold the hydrogen outlet tube at a fitting connection for ten seconds while monitoring the baseline.
3. Tighten the fitting and test it again, repeating as necessary until every connection has passed the ten second test.
4. If the current remains high, hold the hydrogen outlet close to the detector. (*Do not insert the tube into any detector holes.*) If a leak in the detector is indicated, contact Valco.

NOTE: This method may also be used to test for leaks in other parts of the system, but remember – a leak upstream from the column will not cause an immediate baseline change. There must be time allowed for the hydrogen to pass through the column.

Warranty

This Limited Warranty gives the Buyer specific legal rights, and a Buyer may also have other rights that vary from state to state. For a period of 365 calendar days from the date of shipment, Valco Instruments Company, Inc. (hereinafter Seller) warrants the goods to be free from defect in material and workmanship to the original purchaser. During the warranty period, Seller agrees to repair or replace defective and/or nonconforming goods or parts without charge for material or labor, or, at the Seller's option, demand return of the goods and tender repayment of the price. Buyer's exclusive remedy is repair or replacement of defective and nonconforming goods, or, at Seller's option, the repayment of the price.

Seller excludes and disclaims any liability for lost profits, personal injury, interruption of service, or for consequential incidental or special damages arising out of, resulting from, or relating in any manner to these goods

This Limited Warranty does not cover defects, damage, or nonconformity resulting from abuse, misuse, neglect, lack of reasonable care, modification, or the attachment of improper devices to the goods. This Limited Warranty does not cover expendable items. This warranty is VOID when repairs are performed by a nonauthorized service center or representative. For information about authorized service centers or representatives, write Customer Repairs, Valco Instruments Company, Inc, P.O. Box 55603, Houston, Texas 77255, or phone (713) 688-9345. At Seller's option, repairs or replacements will be made on site or at the factory. If repairs or replacements are to be made at the factory, Buyer shall return the goods prepaid and bear all the risks of loss until delivered to the factory. If Seller returns the goods, they will be delivered prepaid and Seller will bear all risks of loss until delivery to Buyer. Buyer and Seller agree that this Limited Warranty shall be governed by and construed in accordance with the laws of the State of Texas.

The warranties contained in this agreement are in lieu of all other warranties expressed or implied, including the warranties of merchantability and fitness for a particular purpose.

This Limited Warranty supercedes all prior proposals or representations oral or written and constitutes the entire understanding regarding the warranties made by Seller to Buyer. This Limited Warranty may not be expanded or modified except in writing signed by the parties hereto.

