



Valco Instruments Co. Inc.

**Universal Electric
Actuator
Instruction Manual
Models EUH, EUD, and EUT**

Firmware revisions CT and previous

Rev 11/18

North America, South America, and Australia/Oceania contact:
VICI Valco Instruments Co. Inc.
800 · 367 · 8424 sales
713 · 688 · 9345 tech
713 · 688 · 8106 fax
valco@vici.com

Europe, Asia, and Africa contact:
VICI VICI AG International
Schenkon, Switzerland
Int + 41 · 41 · 925 · 6200 phone
Int + 41 · 41 · 925 · 6201 fax
info@vici.ch

This page intentionally left blank for printing purposes

Table of Contents

Introduction	
Description	1
Getting Started	
Mounting.....	1
Power Connector Function	1
Basic Operation of the Manual Remote.....	2
Basic Control Functions with the Standard Interface.....	3
Two Positions Modes	3
Multiposition Mode.....	3
Step Command	3
Home Command	3
Optional Serial Interface.....	4
Establishing Serial Control	4
Using the Device ID Feature	5
Setting the Operation Mode.....	5
Mode 1: Two Position With Stops.....	5
Mode 2: Two Position Without Stops.....	6
Mode 3: Multiposition.....	6
Setting the Serial Port Configuration Switch	7
USB Option	7
Serial Communication Protocol	7
Serial Commands	8
Command Reference	9
Optional BCD Interface	14
Hardware Input/Output Protocols	14
Digital Input Protocols	
Binary Coded Decimal (BCD) Input Mode	14
Parallel Input Mode.....	14
Binary Input Mode	14
Pin Signal Definitions.....	15
Additional Digital Input and Output Signals.....	16
Using the Offset Feature.....	17
With BCD Control	17
With Serial Control.....	18
Appendix A: Installing USB Drivers	19
Windows XP	19
Appendix B: Re-Configuring the Actuator with the Manual Remote.....	21
Accessing the Setup Mode	21
Button Functions.....	21
Examples	21
Menu Tree	22
Appendix C: Factory Mode.....	23
Warranty	24

This page intentionally left blank for printing purposes

Introduction

Description

The VICI universal actuator models are designed to work with both two position and multiposition valves, with any number of ports. This is accomplished through simple programming via the manual remote or the optional serial, BCD, or USB interface. The actuator consists of a single unit housing a stepper motor/gearbox assembly and the control components, a universal AC input (100-240 VAC, 50-60 Hz) to 24 VDC power supply, a manual remote, and the interconnecting cables.

Getting Started

Mounting

The actuator should be oriented so that any potential leakage of liquid from the valve or fittings flows away from rather than into the actuator.

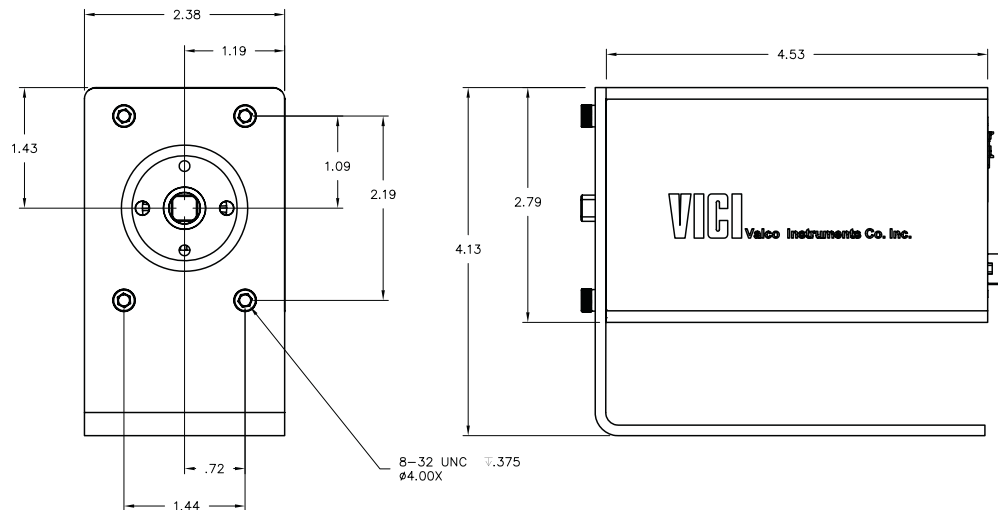

Figure 1: Universal actuator mounting dimensions

Power Connector

Input power (24-28 VDC) is supplied through a coaxial connector: the inner pin is + voltage and the outer pin is ground. The average current requirement is 2.1 amps; standby current draw is 60 milliamps.

The actuator should not share a power supply with other noise-sensitive electronics, as the high current draw could cause problems.

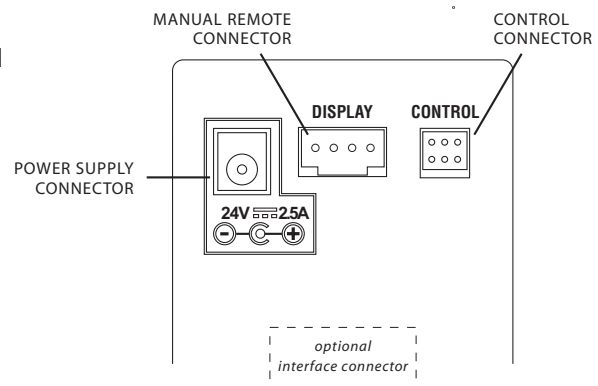

Figure 2: Connections on rear panel

Basic Operation of the Manual Remote

The manual remote provides simple valve positioning capabilities, but in the setup mode, it can be used to execute extensive actuator setup functions. For more information, refer to *Setup Mode: Using the Manual Remote to Configure the Actuator* on page 21.



Do not attempt to enter the setup mode by holding down the two arrow buttons, as with a microelectric actuator. This will open a factory mode (*Appendix C, page 23*), which should be exited without changes by pressing the UP arrow button.

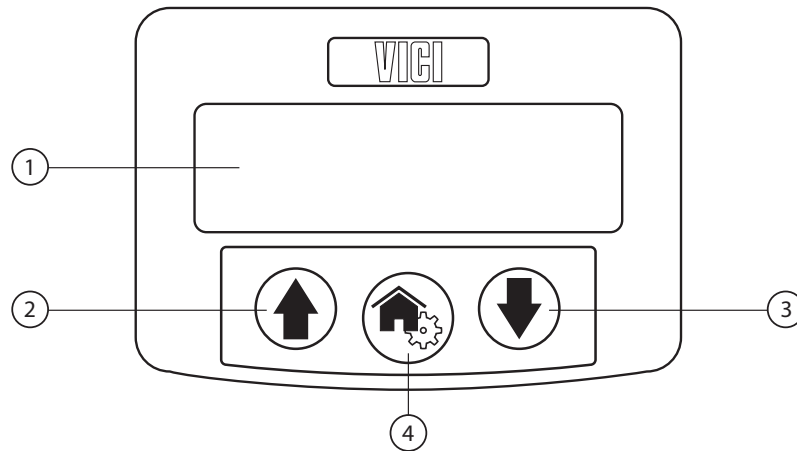

Figure 3: Universal actuator manual remote

1. Display
2. **UP** arrow button
 In *two position* configuration, pressing the UP arrow button moves the actuator to Position B. If it is already in Position B, nothing happens.
 In *multiposition* configuration, pressing the UP arrow button advances the actuator one position; i.e., from 1 to 2, 4 to 5, etc.
3. **DOWN** arrow button
 In *two position* configuration, pressing the DOWN arrow button moves the actuator to Position A. If it is already in Position A, nothing happens.
 In *multiposition* configuration, pressing the DOWN arrow button reverses the actuator one position; i.e., from 2 to 1, 5 to 4, etc.
4. **HOME/SETUP** button
 In *two position* configuration, pressing the HOME button moves the actuator to Position A. If it is already in Position A, nothing happens.
 In *multiposition* configuration, pressing the HOME button sends the actuator to Position 1.
 Pressing and holding the HOME/SETUP button for 5 seconds sends the manual remote into the setup mode. (*See page 21*)



Pressing and holding the HOME button for 5 seconds sends the manual remote into the setup mode. If this occurs accidentally, press the UP arrow to escape and return to normal operation.

Basic Control Functions with the Standard Interface

Basic actuator control functionality facilitates position switching in two position modes, and step and home functions in the multiposition mode. This is done via direct input signals from switch closures, relay contacts, or TTL-compatible interfaces. The control cable has six pins: however, only five are used.

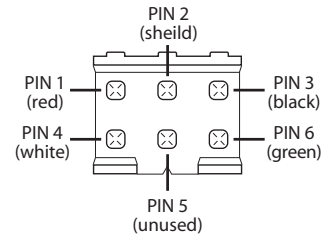

Figure 4:

Standard interface connector (colors reference cable I-25176)

Two position modes

Pins 4 and 6 are digital inputs for switching to Position A and Position B. They can be driven either by 5 volt TTL/CMOS logic or by contact closure to ground (pin 2). In other words, applying a connection (20 msec minimum) between the “A contact” and common moves the injector to position A (inject). The injector does not move when the connection is released. Likewise, providing a contact between the “B contact” and common moves the injector to the B (load) position. Connections must be released before the opposite closure can be applied.

Position feedback is obtained from the A and B outputs. These are 5 volt tolerant, 3.3 volt logic outputs, sourcing and sinking a maximum of 10 milliamperes each. An output will go high (+3.3V) when the valve reaches the respective position.

Pin #	Function
1	B output (3.3 VDC)
2	Common
3	A output (3.3 VDC)
4	B contact
5	Unused
6	A contact

Figure 5: Two position pin assignments

Multiposition mode

Step Command

Applying a connection (20 msec minimum) between the common and “Step” pin causes the actuator to move to the next position in the currently-set direction of rotation. The connection must be opened before another step can be made.

Home Command

Applying a connection between the common and “Home” pins causes the actuator to go to the HOME position (position 1), moving in the currently-set direction of rotation. The connection must be opened before another step can be made.

Pin #	Function
1	Motor Run output
2	Common
3	Home output
4	Step
5	Unused
6	Home

Figure 6: Multiposition pin assignments

Feedback is obtained from the Home and Motor Run and outputs. Pin 3 output goes low when the valve is in the HOME position; pin 1 goes low when the motor is running during execution of a Step or Home command.



For all modes: asserting or reasserting a digital input during a move can cause the move to be aborted and the new position to become the target. Asserting a position multiple times during a move can cause a positioning failure.

Optional Serial Interface

Note: Models with product numbers ending in "A" have been factory-set for RS-232; those ending in "F" were set for RS-485. If you wish to convert an "A" model to an "F" model or vice versa, refer to "Setting the Serial Port Configuration Switch" on page 7.

Establishing Serial Communication

Serial communication requires a terminal emulation or communication software (such as HyperTerminal®, included with Windows®) running on a PC-compatible computer. Set the serial port at 9600 baud, no parity, 8 data bits, 1 stop bit, no hardware or software handshaking.

With the software running, check the bi-directional communication link between the keyboard/monitor of the computer and the serial port by typing `/?<enter>`. If the link is functioning, the following menu will appear on your monitor:

Control Command List

GO[nn]	- Move to nn position
HM	- Move to the first Position
CW[nn]	- Move Clockwise to nn Position
CC[nn]	- Move Counter Clockwise to nn Position
TO	- Toggle Position to Opposite
TT	- Timed Toggle
DT[nnnnn]	- Set Delay time for TT Command
CP	- Returns Current Position
AM[n]	- Sets the Actuator Mode [1] Two Position With Stops, [2] Two Position Without Stops, [3] Multi Position
SB[nnnn]	- Set the Baud Rate to nnnnn
ID[nn]	- Set Device ID nn=(0-9, A-Z)
ID	- Reset ID to none
NP[nn]	- Set the Number of Positions to nn
SM[n]	- Set the Direction [F]orward, [R]everse, [A]uto
LRN	- Learn Stops Location
CNT[nnnnn]	- Set Cycle Counter
VR	- Firmware Version(s)
/?	- Displays This List

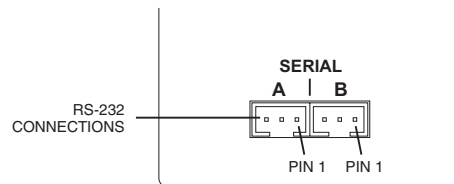

Figure 7: Serial connectors on rear panel

Using the Device ID Feature

When an ID is set, the actuator responds only to commands which begin with the correct ID prefix, and its transmit output is disabled when not in use. This allows up to 10 actuators to be controlled from one computer RS-232 port. A single command can be broadcast to all actuators by using an asterisk (*) as the command prefix. In this usage, any broadcast command which elicits a response from the serial port (such as *VR or *ID) will elicit a combined and unintelligible response.

Note: RS-232 actuators (product number ending in "A") are shipped with the ID feature disabled. RS-485 actuators (product number ending in "F") are set to the default of "Z". All RS-485 communications require an ID, and must be preceded with a '/': *i.e.* /ZVR<enter>.

For permanent multidrop applications, the RS-485 mode is the preferred solution. However, just as RS-232 control requires the host to have an RS-232 serial port, the PC host or control system must have an RS-485 port to communicate with the actuator in the RS-485 mode. Plug-in PCI cards with RS-485 ports or adaptors that change an RS-232 signal to an RS-485 signal are available from several common electronic manufacturers. If your computer lacks a serial port, adaptors which convert USB ports to RS-232 or to RS-485 are also readily available.



When installing or replacing actuators on a shared serial port, make sure that no two devices have been set to the same ID number.

To set the device ID:

1. Remove all of the actuators from the serial daisy chain except the one for which you are setting the ID.
2. To *set* an ID, type **IDn**<enter>, where *n* is the new ID, from 0 to 9 or A to Z.
To *change* an ID, type **iIDn**<enter>, where *i* is the current ID and *n* is the new ID.
To *disable* the ID feature, type **iID***<enter>, where *i* is the current ID.

Setting the Operation Mode

This section employs some simple serial commands to complete a basic configuration of the valve/actuator combination. A more advanced discussion of serial control begins in the next section.

Mode 1: Two Position With Stops (*factory default*)

This is the proper mode for most two position applications. (*Note exceptions in the next section.*) In this mode, the actuator automatically finds the correct positions using a combination of the valve's mechanical stops and the actuator's quadrature encoder.

To set up the actuator in this mode:

1. Make sure that the valve is mounted on the actuator with the stop pin all the way against the Position A stop. You can check by loosening the clamp ring and turning the valve counterclockwise by hand, then tightening the clamp ring. (For orientation, refer to the **Figure 8** at the bottom of the next page.) If it will not move, it was already against the stop.
2. Type **AM1**<enter> to set the actuator to Mode 1, Two Position With Stops.
3. Type **LRN**<enter>. The actuator will search for the valve stops, "learning" and recording the locations. When the process is completed, the valve is set to position A.

Mode 2: Two Position Without Stops

In this mode the actuator uses only the encoder to find the correct position. This mode is used for the Cheminert Model C32 valve and for custom applications involving on/off valves or any other two position valve that literally has no mechanical stops.



Installing a valve with mechanical stops while in this mode could damage the actuator.

To set up the actuator in this mode:

1. Make sure that the valve is already mounted on the actuator.
2. Type **AM2**<enter> to set the actuator to Mode 2, Two Position without Stops.
3. Type **NPn**<enter>, where *n* is the number of ports the valve has. For example, **NP6**<enter> tells the actuator that the valve has 6 ports, so the actuator can calculate the appropriate number of degrees from position A to position B. In this example, that distance is 60 degrees (360 / 6 ports).

Mode 3: Multiposition

Select this mode for any Valco or Cheminert multiposition valve or selector with up to 32 positions. The actuator will use its encoder to calculate the proper rotation to find each position.



Installing a valve with mechanical stops while in this mode could damage the actuator.

To set up the actuator in this mode:

1. Make sure that the valve is already mounted on the actuator.
2. Type **AM3**<enter> to set the actuator to Mode 3, Multiposition.
3. Type **NPnn**<enter>, where *nn* is the number of positions the valve has (must be an even number between 2 and 40). For example, for a 10 position valve, type **NP10**<enter> to set the number of positions to 10.



Do not confuse the number of positions with the number of ports. Many multiposition valves have more than one port associated with each position.

4. Type **HM**<enter> to send the valve to its HOME position (position 1).

In this mode, counterclockwise moves the actuator in the “positive” direction—position 1 to position 2. The clockwise direction is “negative”, moving in the direction of position 2 to position 1.

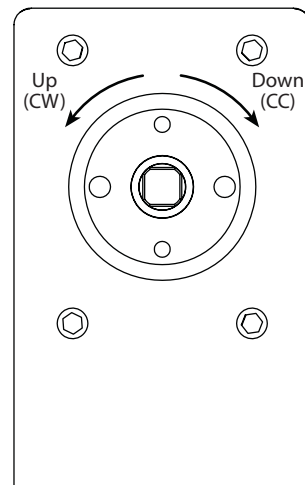

Figure 8: Actuator orientation for directional references

Setting the Serial Port Configuration Switch

Models with product numbers ending in “A” have been factory-set for RS-232; those ending in “F” were set for RS-485. An “A” model can be changed to an “F” model, or vice versa, by resetting the serial port configuration switch.

Note when switching from RS-232 to RS-485:

As discussed in the “Using the Device ID Feature” on page 7, all RS-485 communications require an ID. If the actuator has had an ID set previously, that ID will be recalled and retained. Otherwise, the ID will be set to the factory default value of “Z”.

To reset the switch:

1. Remove the 4 screws from the front (valve side) of the actuator.
2. Carefully slide the assembly out of the enclosure. We recommend that the enclosure be opened in a static-free environment following all proper ESD protection techniques.
3. Locate the slide switch marked “232 <- -> 485”, and set it to the desired position..

Note: The switch labeled “Termination On <- -> Off” is typically left in the Off position. Unless the wiring from the host control to the device is very long and it is the last device at the end of a signal chain of devices, it is recommended that this switch is left in the Off position.

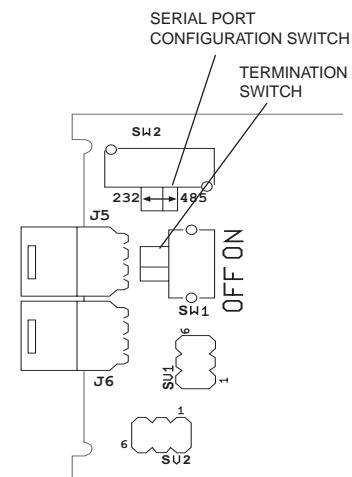

Figure 9: Serial port configuration switch

USB Option

The USB interface installs as a virtual COM port (VCP). The VCP driver causes the universal actuator to appear as an additional COM port available to the PC, so application software can access the actuator in the same way it accesses a standard COM port. Refer to “Appendix A: Installing USB Drivers”, on page 19.

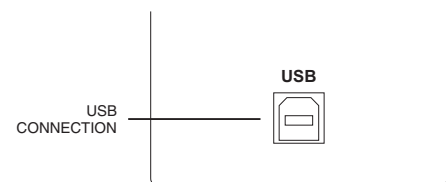
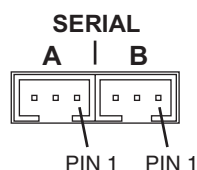

Figure 10: USB connector on rear panel

Serial Communication Protocol

Serial communication is based on an ASCII string protocol. Carriage Return (OD hex) and Line Feed (OA hex) characters parse the communications by defining the end of each command. A three-pin connector is used for the serial interface: pin assignments are indicated below. Software flow control (Xon/Xoff) and hardware handshaking are not supported. The table on the next page describes and explains all the commands available. A fuller explanation follows.



Pin #	RS-232	RS-485	DB9*
1	Ground	Ground	5
2	Transmit to host	A (-)	2
3	Receive from host	B (+)	3

*For VICI cable I-22697

Serial Commands		
Command	Modes*	Description
AM <enter>	1, 2, 3	Displays the current actuator mode
AM <i>nn</i> <enter>	1, 2, 3	Sets the actuator mode to [1] two position with stops, [2] two position without stops, or [3] multiposition
CC <enter>	1, 2	Sends the actuator to Position B
CC <i>nn</i> <enter>	3	Sends the actuator counterclockwise to position <i>nn</i> (from 1 to NP)
CNT <enter>	1, 2, 3	Displays the current value in the actuation counter
CNT <i>nnnnn</i> <enter>	1, 2, 3	Sets the actuation counter from 0 to 65535. (For example, to reset the counter, type CNT0 <enter>)
CP <enter>	1, 2, 3	Displays the current position
CW <enter>	1, 2	Sends the actuator to Position A
CW <i>nn</i> <enter>	3	Sends the actuator clockwise to position <i>nn</i> (from 1 to NP)
DEL <i>n</i> <enter>	1, 2, 3	Sets the command delimiter to [1] CR (default), [2] LF, or [3] CRLF
DT <enter>	1, 2	Displays the current delay time in milliseconds
DT <i>nnnnn</i> <enter>	1, 2	Sets the delay time from 0 to 65,000 milliseconds
GO <i>nn</i> <enter>	1, 2	Sends the actuator to position <i>n</i> , where <i>n</i> is A or B
	3	Sends the actuator to position <i>nn</i> (from 1 to NP) via the shortest route
HM <enter>	3	Moves the valve to position 1 (home)
ID / <i><enter></i>	1, 2, 3	Sets the ID of the actuator to / (Must be 0-9 or A-Z)
ID <enter>	1, 2, 3	Resets the ID to None
IFM <i>n</i> <enter>	1, 2, 3	Sets the interface response mode to [0] no response string when an action command is sent, [1] basic response to action commands, or [2] extended response to action commands (needed for BCD interface)
LG <i>n</i> <enter>	1, 2, 3	Sets the interface response mode to [0] no extra characters, or [1] longer response string to be fully backwards compatible with VICI microelectric actuators
LRN <enter>	1	Forces the actuator to find the stops on a newly installed valve. (Note: The valve must be installed before this command is sent.)
NP <enter>	1, 2, 3	Displays the number of positions the actuator is currently set to index
NP <i>nn</i> <enter>	2	Sets the number of ports (<i>nn</i>) for the current valve. (Must be an even number between 2 and 40)
	3	Sets the number of positions (<i>nn</i>) for the current valve. (Must be an even number between 2 and 40)
SB <enter>	1, 2, 3	Displays the current baud rate
SB <i>nnnn</i> <enter>	1, 2, 3	Sets the baud rate to 48(00), 96(00), 192(00), 384(00), 576(00), or 1152(00). The parity setting, number of data bits, and number of stop bits cannot be changed.
SM <enter>	3	Displays the current default rotational direction
SM / <i><enter></i>	3	Sets the default rotational direction to [F] for forward rotation, [R] for reverse rotation, or [A] to automatically choose the shortest route.
SO <enter>	1, 2, 3	Displays the current offset value
SO <i>nn</i> <enter>	1, 2, 3	Sets the offset value of the first position to be any number from 1 to 96 minus the total number of positions. Example: for a 10 position valve, the offset can be set from 1 to 86.
STAT <enter>	1, 2, 3	Displays the status of the actuator
TM <enter>	1, 2, 3	Displays the amount of time required for the previous move, in milliseconds
TO <enter>	1, 2	Toggles the actuator to the opposite position
TT <enter>	1, 2	Toggles the actuator to the opposite position, waits a preset delay time, then rotates back to the original position.
VR <i>n</i> <enter>	1, 2, 3	Displays the current firmware version for [NULL], the main PCB, or [2] the serial interface PCB.
/? <enter>	1, 2, 3	Displays a list of valid commands

* Modes are described on pages 5-6.

Notes: In this chart, *nn* represents numbers to be entered and *l* represents letters.

<enter> = CR(0x0D)

Command Reference

- AM**[*n*] Sets the actuator mode or displays the current mode,
where *n* = 1 = two position with stops (factory default)
2 = two position without stops
3 = multiposition
NULL = returns (via the serial port) the current mode
- Modes available: All (modes are discussed on pages 5 and 6)
- Examples**
- Command: **AM1**<enter>
Sets the actuator mode to two position with stops
- Command: **AM**<enter>
Returns: **AMn** [0x0D] (*n* = current mode setting)
- CC**[*nn*] Moves the actuator in a counterclockwise direction,
where *nn* = 1 to NP (See also **NP** command)
- Modes available: All (with restrictions – in two position modes, *nn* is not allowed)
- Examples** (multiposition, mode 3)
- Command: **CC3**<enter>
Moves the actuator counterclockwise to position 3
- Command: **CC**<enter>
Moves the actuator counterclockwise one position
- Example** (two position, modes 1 and 2)
- Command: **CC**<Enter>
Moves the actuator from position A to position B. If the actuator is already in Position B, the command is ignored.
- CNT**[*nnnnn*] Displays the current number of actuation cycles, or resets the counter to zero,
where *nnnnn* = 0 to 65535
- Modes available: All
- In two position modes (1 and 2), the counter is incremented every time the valve moves. In the multiposition mode (3), the counter is incremented by the number of positions the valve moves; *i.e.*, moving from position 2 to position 4 increments the cycle count by 2.
- Examples**
- Command: **CNT**<enter>
Returns: **CNTnnnnn** [0x0D] (*nnnnn* = current valve of counter)
- Command: **CNT0**<enter>
Resets the cycle counter to 0 (zero)
- Command: **CNT100**<enter>
Sets the cycle counter to 100
- CP** Displays the current position of the actuator
- Modes available: All (see below)
- Example** (two position, modes 1 and 2)
- Command: **CP**<enter>
Returns: **CP***l* [0x0D] (*n* = 'A' or 'B') (*l* = current position)
- Example** (multiposition, mode 3)
- Command: **CP**<enter>
Returns: **CPnn** [0x0D] (*nn* = current position)

- CW**[*nn*] Moves the actuator in a clockwise direction, where *nn* = 1 to NP (see also **NP** command)
- Modes available: All (with restrictions – in two position modes, *nn* is not allowed)
- Examples** (multiposition, mode 3)
- Command: **CW**<enter>
Moves the actuator clockwise one position
- Command: **CW3**<enter>
Moves the actuator clockwise position 3
- Example** (two position, modes 1 and 2)
- Command: **CW**<Enter>
Moves the actuator from position B to position A. If the actuator is already in Position A, the command is ignored.
- DT**[*nnnn*] Sets a delay interval before the actuator automatically returns to its previous position, where *nnnn* = 0 – 65535 (milliseconds) (See also **TT** command)
- Modes available: Two position (1 and 2)
- Examples**
- Command: **DT**<enter>
Returns **DTnnnn** [0x0D] (*nnnn* = current delay setting)
- Command: **DT0**<enter>
Sets the delay time to 0 and disables the TT command
- Command: **DT1000**<enter>
Sets the delay timer to 1000 milliseconds (1 second)
- GO**[*nn*] Tells the actuator to go to position *nn*, Where *nn* = 1 to NP (multiposition, mode 3)
= 'A' or 'B' (two position, modes 1 and 2)
(See also **NP** and **SM** commands)
- Modes available: All (see below)
- Examples** (two position, modes 1 and 2)
- Command: **GO**<enter>
Toggles the actuator to the other position
- Command: **GOB**<enter>
Moves the actuator from position A to position B
- Examples** (multiposition, mode 3)
- Command: **GO**<enter>
Advances the actuator to the next position
- Command: **GO3**<enter>
Moves the actuator to position 3 in the direction set by the SM command
- HM** Moves the actuator to position 1. If the actuator is already in position 1, the command is ignored.
- Modes available: Multiposition (3)
- Example**
- Command: **HM**<enter>
Moves the actuator from the current position to position 1

- IFM**[*n*] Sets the actuator response mode to [*n*], determining how the actuator responds to action commands, where *n* = 0 = no response string
 1 = basic response string
 2 = extended response string (required for BCD interface)
- Modes available: All
- Example**
 Command: **IFM0**<enter>
 Turns off all responses to action commands
- LG**[*n*] Sets the actuator response mode to [*n*],
 where *n* = 0 = no extra characters in the response string
 1 = response includes " = ", to emulate a VICI microelectric actuator
- Modes available: All
- Example**
 Command: **LG1**<enter>
 Sets response to include extra characters
- LRN** Causes the actuator to "learn" and record the locations of a two position valve's physical stops. When the process is completed, the valve is set to position A.
- Modes available: Two position with stops (mode 1) (factory default)
 See also **AM** command
- Example**
 Command: **LRN**<enter>
 Initiates the learning process
- NP**[*nn*] Sets or displays the current setting for the number of ports (two position) or positions (multiposition) on the valve attached to the actuator, where *nn* = 2 – 40 (must be an even number).
- Modes available: Two position without stops (2), multiposition (3)
- Example** (two position, mode 2)
 Command: **NP**<enter>
 Returns: **NPnn** [0x0D] (*nn* = current setting for number of ports)
- Example** (multiposition, mode 3)
 Command: **NP6**<enter>
 Sets the number of positions to 6
- SB**[*nnnn*] Sets the baud rate of the serial port, where *nnnn* = 48, 96, 192, 384, 576, or 1152
- Modes available: All
- Example**
 Command: **SB192**<enter>
 Sets the baud rate for the serial port to 19200
- SM**[*l*] Sets the direction of rotation for the actuator, where *l* = F = Forward (toward the next highest numeric position)
 R = Reverse (toward the next lowest numeric position)
 A = Auto (shortest route)

If an actuator set to F (forward direction) is in position 4 and the command is sent to go to position 3, it will go all the way around until it reaches position 3 instead of taking one step backwards. For the actuator to calculate the direction which involves the least movement, the direction must be set to A (shortest route).

Modes available: Multiposition (3)

Examples

Command: **SM**<enter>
Returns: **SMI** [0x0D] (*I* = current rotation direction)

Command: **SMF**<enter>
Sets the actuator to only move in the forward direction

SO[*nn*] Sets the offset value of the first position to be any number from 1 – 96, where *nn* = 1 – 96.

This feature makes it possible to control more than one actuator with a single computer. The actuator's SO value can be set from "1" to "96", minus the current NP value (the number of positions the actuator is set to index). Once an SO value is set, that value is the first (or lowest) position an actuator will recognize. The factory SO setting is "1", so an actuator with an NP value of 10 responds to move commands for positions "1" to "10". If the SO value is changed to "10", the actuator will respond only to move commands for positions "10" through "19". For any setting of SO and NP, the lowest valid position will be the SO value and the highest valid position will be the SO value plus the NP value minus 1; *i.e.*, the actuator will respond to commands for position SO through position {SO + NP - 1}. Refer to "Using the Offset Feature" on page 19.

Modes available: All (but used primarily in mode 3, multiposition)

Examples

Command: **SO**<enter>
Returns **SO***nn* [0x0D] (*nn* = current offset value)

Command: **SO10**<enter>
Sets the offset value to 10. The valve will now start counting as if 10 = position 1

STAT Returns (via the serial port) the following information,
CP = current position
AM = current mode
NP = number of ports (modes 1 and 2) or positions (mode 3) on the current valve

(See also **CP**, **AM**, and **NP** commands)

Modes available: All

Example

Command: **STAT**<enter>
Returns: Current status of the actuator

TM Returns the amount of time, in milliseconds, required by the previous move

Modes available: All

Example

Command: **TM**<enter>
Returns: Number of milliseconds taken to move from the previous position to the current position

- TO** Toggles the actuator to the opposite position from its current position; *i.e.*, if the actuator is currently in Position B, it will toggle to Position A.
- Modes available: Two position (1 and 2)
- Example**
Command: **TO**<enter>
Causes the actuator to toggle from one position to the other
- TT** Timed toggle: the actuator will toggle from its current position to the opposite, wait for a programmed amount of time, then toggle back to its original position.
Note: This command is ignored if DT=0. (See also **DT** command)
- Modes available: Two position (1 and 2)
- Example**
Command: **TT**<enter>
The actuator will initiate the timed toggle procedure
- VR n** Reports the current firmware version, where $n = [\text{null}]$ for the main PCB, or $n = 2$ for the serial interface PCB.
- Modes available: All
- Examples**
Command: **VR**<enter>
Returns: Current revision of the main PCB firmware
Command: **VR2**<enter>
Returns: Current revision of the serial PCB firmware
- /?** Displays the list of the primary commands for the actuator. The list is similar to the serial command table above but is not inclusive of all the commands.
- Modes available: All
- Example**
Command: **/?**<enter>
Returns: The list of commands for the actuator

Optional BCD Interface

Hardware Input / Output Protocols

The digital interface is made through a 26 pin connector which also provides power (+5 volts/100 ma maximum) and ground outputs. The ground should be connected to the control system to maintain commonality between the actuator and the controlling device. If you intend to provide your own power supply, make sure that it has an isolated output or that it shares a common ground with the controlling system.

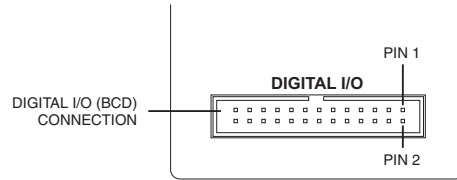

Figure 11: Digital I/O connector on rear panel

Digital input/output control of the actuator is designed for simplicity and flexibility of function. The simplest control of the actuator can be accomplished in modes 1 and 2 with a single control line for the STEP function. Mode 3 requires only two output control lines – STEP and HOME. The chart on the next page lists other control options.

The inputs are held to a logical high (+5 volts) by pull-up resistors, and are designed to be driven low either by contact closure, 5 volt digital logic, or open collector transistor outputs. The signal polarity is defined as “negative true” – asserting the signal involves shorting the signal (in the case of contact closure) or driving it (in the case of logic or transistor signals) to within 0.8 volts of ground potential. These input signals must be at least 30 milliseconds in duration.

The BCD outputs are also “negative true” signals driven by standard high speed CMOS gates, capable of driving standard logic input gates. If the actuator stops out of position due to a stuck valve, the BCD output is set to “0” (all lines high for a negative true output). The motor run, rotational direction, and error signals are positive true outputs..

Digital Input Protocols

The input modes are selected during factory setup/programming.

Binary Coded Decimal (BCD) input mode (default)

For the 96 possible input positions, all 8 digital input data lines are required. Refer to the chart on the next page for the signal line definitions.

Parallel Input Mode

In this mode, the data input lines are redefined so that each input line equates to only one actuator position; any and all combinations of data input lines are invalid. This mode can support only 8 positions: 1 BCD = position 1; 2 BCD = position 2; 4 BCD = position 3; 8 BCD = position 4; 10 BCD = position 5; 20 BCD = position 6; 40 BCD = position 7; and 80 BCD = position 8. The offset value SO is set to 1, and since the number of positions is limited to 8, any user-set NP value greater than 8 will revert to 8. (See the chart on the next page for more explanation of NP and SO.)

Binary Input Mode

This mode allows up to 128 possible input positions. All 8 digital input data lines are required. Refer to the chart on the next page for the signal line definitions.

Pin	Color	Signal	Direction	Pin	Color	Signal	Direction
1	brown	Home	Input	14	yellow	4 BCD	Output
2	red	Motor run	Output	15	green	20 BCD	Output
3	orange	Step	Input	16	blue	2 BCD	Output
4	yellow	Error	Output	17	violet	10 BCD	Output
5	green	Manual Dir.	Input	18	gray	1 BCD	Output
6	blue	Direction	Output	19	white	80 BCD	Input
7	violet	Auto Dir.	Input	20	black	8 BCD	Input
8	gray	Data latch	Input	21	brown	40 BCD	Input
9	white	+5 VDC 100 ma	Output	22	red	4 BCD	Input
10	black	Ground	Output	23	orange	20 BCD	Input
11	brown	80 BCD	Output	24	yellow	2 BCD	Input
12	red	8 BCD	Output	25	green	10 BCD	Input
13	orange	40 BCD	Output	26	blue	1 BCD	Input

Pin signal definitions for the Digital Input/Output cable

Mode:	SD0	SD2	SD3	Data Input Lines							
Input type:	BCD	Parallel	Binary	1 BCD	2 BCD	4 BCD	8 BCD	10 BCD	20 BCD	40 BCD	80 BCD
Position:	1	1	1	X	-	-	-	-	-	-	-
	2	2	2	-	X	-	-	-	-	-	-
	3	*	3	X	X	-	-	-	-	-	-
	4	3	4	-	-	X	-	-	-	-	-
	5	*	5	X	-	X	-	-	-	-	-
	6	*	6	-	X	X	-	-	-	-	-
	7	*	7	X	X	X	-	-	-	-	-
	8	4	8	-	-	-	X	-	-	-	-
	9	*	9	X	-	-	X	-	-	-	-
	*	*	10	-	X	-	X	-	-	-	-
	*	*	11	X	X	-	X	-	-	-	-
	*	*	12	-	-	X	X	-	-	-	-
	*	*	13	X	-	X	X	-	-	-	-
	*	*	14	-	X	X	X	-	-	-	-
	*	*	15	X	X	X	X	-	-	-	-
	10	5	16	-	-	-	-	X	-	-	-
	11	*	17	X	-	-	-	X	-	-	-
	12	*	18	-	X	-	-	X	-	-	-
	13	*	19	X	X	-	-	X	-	-	-
	14	*	20	-	-	X	-	X	-	-	-
	15	*	21	X	-	X	-	X	-	-	-
	16	*	22	-	X	X	-	X	-	-	-
	17	*	23	X	X	X	-	X	-	-	-
	18	*	24	-	-	-	X	X	-	-	-
	19	*	25	X	-	-	X	X	-	-	-
	*	*	26	-	X	-	X	X	-	-	-
	*	*	27	X	X	-	X	X	-	-	-
	*	*	28	-	-	X	X	X	-	-	-
	*	*	29	X	-	X	X	X	-	-	-
	*	*	30	-	X	X	X	X	-	-	-
	*	*	31	X	X	X	X	X	-	-	-
	20	6	32	-	-	-	-	-	X	-	-
<i>Code sequence break</i>											
40	7	64	-	-	-	-	-	-	X	-	
<i>Code sequence break</i>											
80	8	128	-	-	-	-	-	-	-	X	

Pin signal definitions for the various input modes

Additional Digital Input and Output Signals

Data Latch (*input*)

toggling this signal from high to low (hold the signal low for a minimum of 5 ms) will cause the actuator to read the BCD Input signals. Once the signals are read, the actuator will then attempt to move to the position indicated on the BCD Input signals.

BCD Signals (*output*)

These represent the current position data in the same format used as the Input protocol.

Note: The BCD Output Signals are only updated after the motor has finished moving (see **Motor Run** below) and if there is no error (see **Error** below).

Step (*input*)

toggling this line from high to low (hold the signal low for a minimum of 5 ms) causes the actuator to advance one position.

Home (*input*)

toggling this line from high to low (hold the signal low for a minimum of 5 ms) moves the actuator to the Home (or first) position.

Manual Direction (*input*)

When the signal is high, the actuator will move in a forward direction. For example, when moving from position 3 to position 4, it will move the shortest distance between the two positions. When the signal is low the actuator will move in a reverse direction; when moving from position 3 to position 4, it will move the longest distance between the two positions.

Auto Direction (*input*)

When the signal is high, the Manual Direction signal dictates how the actuator moves to different positions. When the signal is low, the actuator will calculate the shortest direction between two positions and move in that direction.

Motor Run (*output*)

When the signal is high, the motor is in an Off state. When the signal is low, the motor is in an On state (moving).

Error (*output*)

When the signal is high, the actuator encountered an error with the last move request. When the signal is low, no error was detected.

Notes:

The system considers a move request for the current position to be an error, since the motor does not move.

Error signals are cleared after the next successful move.

Direction (*output*) – Factory test output.

Using the Offset Feature

This feature makes it possible to control more than one actuator without increasing the number of BCD or serial input lines. The actuator's SO value can be set from "1" to "96", minus the current NP value (the number of positions the actuator is set to index). Once an SO value is set, that value is the first (or lowest) position an actuator will recognize. The factory SO setting is "1", so an actuator with an NP value of 10 responds to move commands for positions "1" to "10". If the SO value is changed to "10", the actuator will respond only to move commands for positions "10" through "19". For any setting of SO and NP, the lowest valid position will be the SO value and the highest valid position will be the SO value plus the NP value minus 1; *i.e.*, the actuator will respond to commands for position SO through position {SO + NP - 1}.

The examples below describe a system that will step sequentially from 1 through 31 with a single instruction. However, note that when positions are selected in a random sequence, position 16 must always be requested before any positions higher than 16 are selected. **Figure 12** helps illustrate this: since both actuators respond to a command to go to position 16, stream 16 will flow through valve 1/port 1, out the common port of valve 2, into valve 1/port 16, and out of the common port of valve 1. Thereafter, any stream select command that is above 16 will move only valve 2; when a move command for a position less than 16 is given, valve 1 will move and cut off all flow from valve 2.

With BCD Control

Here is how this can be feature can be used to set up a 31-stream stream selection system using six dedicated BCD lines and two 16-position valves and actuators. Refer to "Using the Manual Remote to Configure the Actuator" on page 3 as required.

1. Use the manual remote to enable the auto-latching feature on both actuators. This eliminates the need for a data latch signal.
2. Use the manual remote to assign the second actuator an offset value of "16", giving it a valid position range of 16 to 31.
3. Use a piece of tubing to connect port 16 of the first valve (on the actuator still carrying the factory-default offset value of "1") to the common port of the valve on the second actuator (which now has an offset value of "16").
4. Connect streams 1 through 15 to ports 1 through 15 on the first valve, and streams 16 through 31 to ports 1 through 15 on the second valve.

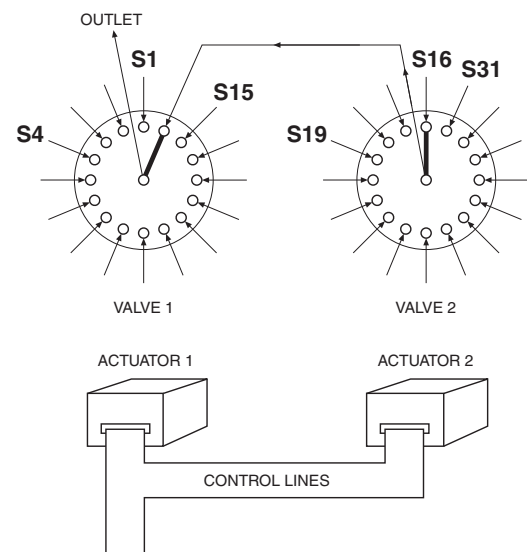

Figure 12: Using the Offset feature

With Serial Control

Here is how this can be feature can be used to set up a 31-stream stream selection system using two 16-position valves and two actuators serially daisy-chained together. Refer to the chapter entitled "Optional Serial Interface" (beginning on page 6) as required.

1. Configure the second actuator using the command **SO16**, giving it a valid position range of 16 to 31.
2. Use a piece of tubing to connect port 16 of the first valve (on the actuator still carrying the factory-default offset value of "1") to the common port of the valve on the second actuator (which now has an offset value of "16").
3. Connect streams 1 through 15 to ports 1 through 15 on the first valve, and streams 16 through 31 to ports 1 through 15 on the second valve.

Appendix A: Installing USB Drivers

Windows XP

1. Connect the actuator to a USB port on your PC. The Found New Hardware Wizard will pop up on your screen.



2. Select "Install from a list or specific location (Advanced)" as shown below. Click Next to continue.



3. Select "Search for the best driver in these locations" and enter the file path in the combo box or browse to it by clicking the browse button. Once the file path has been entered in the box, click Next to proceed.



- When Windows XP has found the required files, the screen below will be displayed while the files are being copied.



- Windows should then display a message indicating that the installation was successful. Click Finish to complete the first part of the installation.



- The Found New Hardware Wizard will launch automatically to install the COM port emulation drivers. As above, select "No, not at this time" from the options, then click Next to proceed.



- Repeat steps 2 - 6 to install the COM port emulation drivers.

Appendix B: Setup Mode: Using the Manual Remote to Configure the Actuator

In the absence of an optional RS-232, USB, or serial interface, the manual remote can be used to perform extensive actuator setup functions.

Accessing the Setup Mode

To access the setup mode, press and hold the HOME/SETUP button for 5 seconds.

Button Functions

- When a screen appears, a line will be highlighted. Use the UP and DOWN arrow keys to highlight a different line.
- When the desired line is highlighted, press the HOME/SETUP button to enter that value.
- For parameters such as number of ports or positions, use the arrow keys to toggle up and down to the desired value, which is then entered by pressing the HOME/SETUP button.
- Only two menus—the Interface Setup and Baudrate—have more than three options. Use the arrow keys to scroll down to additional screens to select the desired value or parameter.
- The UP arrow key also functions as a back button.

A complete menu tree appears on the next page.

Examples

To configure the actuator for a 10 position multiposition valve:

1. On the main menu, use the arrow buttons to highlight Valve Setup. Press the HOME/SETUP button.
2. Use the DOWN arrow button to highlight Multiposition. Press the HOME/SETUP button.
3. Use the UP and DOWN arrow buttons to move through the numbers until 10 is showing. Press the HOME/SETUP button.

Main Menu
1. Valve Setup
2. Interface Setup
3. Information

Valve Menu
1. Two position
2. Multiposition

Set positions:
10

In the multiposition mode, “counterclockwise” means that the actuator moves in the “positive” direction—position 1 to position 2. The clockwise direction is “negative,” moving in the direction of position 2 to position 1.

To set our just-configured 10 position actuator to move in a clockwise direction:

1. On the main menu, use the arrow buttons to highlight Valve Setup. Press the HOME/SETUP button.
2. Use the DOWN arrow button to highlight Move Direction. Press the HOME/SETUP button.
3. Use the DOWN arrow button to highlight Clockwise. Press the HOME/SETUP button.

Main Menu
1. Valve Setup
2. Interface Setup
3. Information

Multiposition Menu
1. Set positions
2. Move Direction
3. Set Offset

Move Direction
1. CounterClockwise
2. Clockwise
3. Shortest

Menu Tree

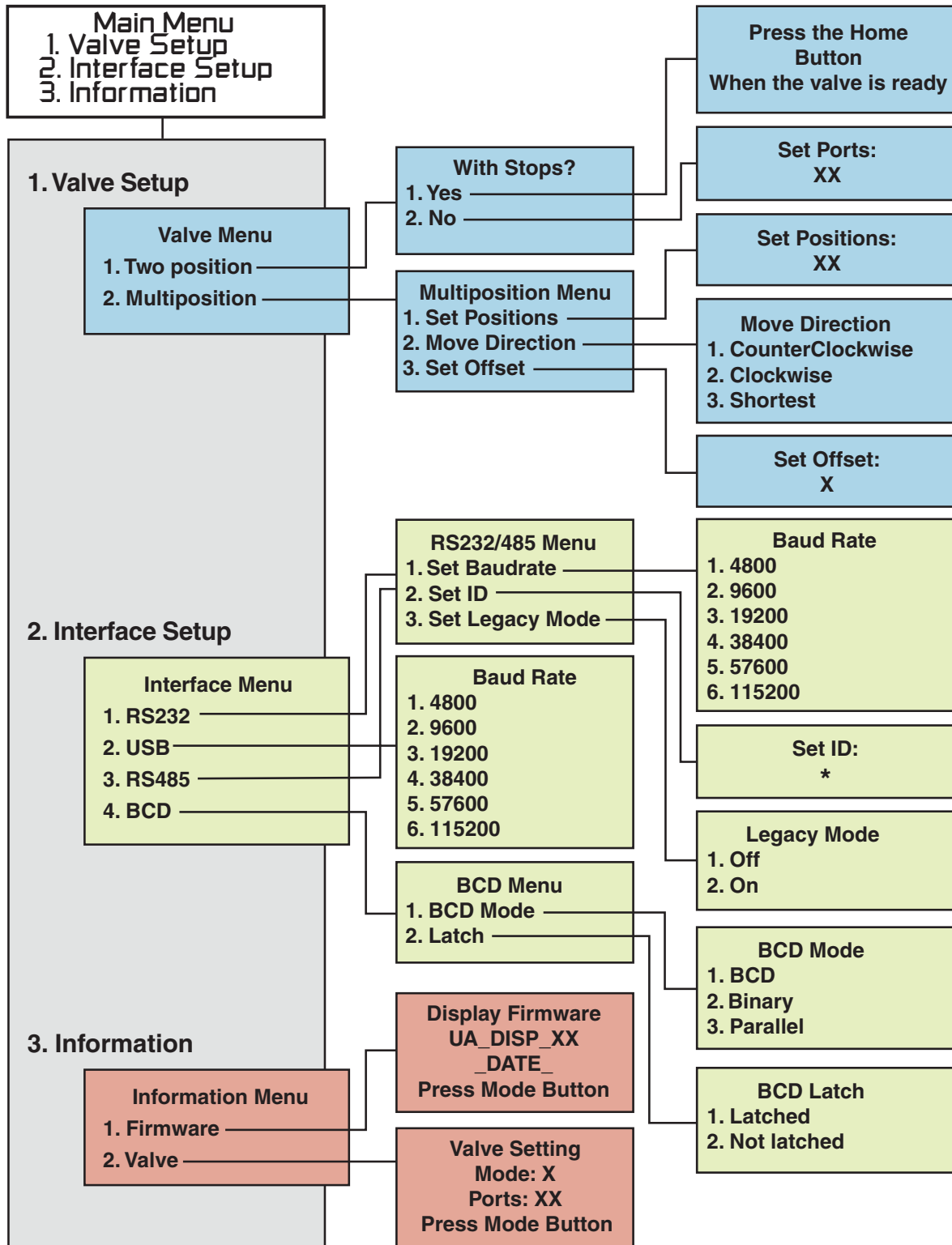

Appendix C: Factory Mode

The Factory mode allows access to basic parameters which are set at the factory. *These parameters should not be altered by the user except via direct consultation with a VICI Technical Support representative.*



If the Factory mode is entered accidentally, press the UP arrow button to escape and return to normal operation.

Menu Tree

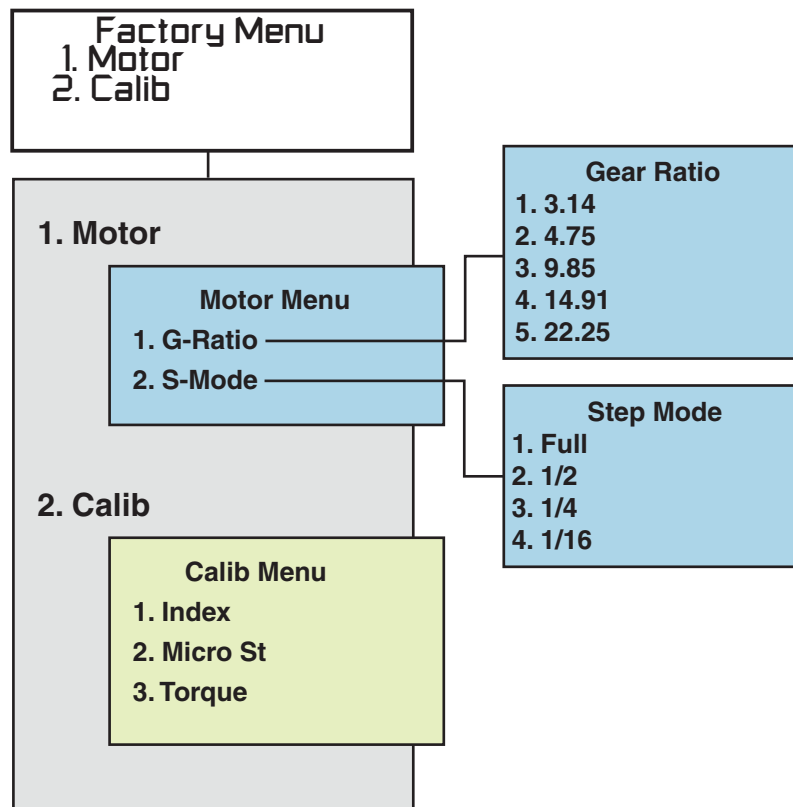

Warranty

This Limited Warranty gives the Buyer specific legal rights, and a Buyer may also have other rights that vary from state to state. For a period of 365 calendar days from the date of shipment, Valco Instruments Company, Inc. (hereinafter Seller) warrants the goods to be free from defect in material and workmanship to the original purchaser. During the warranty period, Seller agrees to repair or replace defective and/or nonconforming goods or parts without charge for material or labor, or, at the Seller's option, demand return of the goods and tender repayment of the price. Buyer's exclusive remedy is repair or replacement of defective and nonconforming goods, or, at Seller's option, the repayment of the price.

Seller excludes and disclaims any liability for lost profits, personal injury, interruption of service, or for consequential incidental or special damages arising out of, resulting from, or relating in any manner to these goods

This Limited Warranty does not cover defects, damage, or nonconformity resulting from abuse, misuse, neglect, lack of reasonable care, modification, or the attachment of improper devices to the goods. This Limited Warranty does not cover expendable items. This warranty is VOID when repairs are performed by a nonauthorized service center or representative. For information about authorized service centers or representatives, write Customer Repairs, Valco Instruments Company, Inc, P.O. Box 55603, Houston, Texas 77255, or phone (713) 688-9345. At Seller's option, repairs or replacements will be made on site or at the factory. If repairs or replacements are to be made at the factory, Buyer shall return the goods prepaid and bear all the risks of loss until delivered to the factory. If Seller returns the goods, they will be delivered prepaid and Seller will bear all risks of loss until delivery to Buyer. Buyer and Seller agree that this Limited Warranty shall be governed by and construed in accordance with the laws of the State of Texas.

The warranties contained in this agreement are in lieu of all other warranties expressed or implied, including the warranties of merchantability and fitness for a particular purpose.

This Limited Warranty supercedes all prior proposals or representations oral or written and constitutes the entire understanding regarding the warranties made by Seller to Buyer. This Limited Warranty may not be expanded or modified except in writing signed by the parties hereto.